



MOTOR VEHICLE

THEFT CLAIM REPORT

Please retain this page for your information

ABOUT YOUR CLAIM

- We will contact you as quickly as possible about your claim.
- For most claims we will check the circumstances and the damage before we have repairs authorised and paid for.
- We need to handle everything related to your claim.
- We may need to get a police report.
- Please refer to your policy booklet for more information about how your claim will be handled.
- Please answer the questions on GST at Question 6.
- If you have any questions about your claim please contact CGU Insurance on 13 24 80 (13 CGU 0).

REPAIRER OPTIONS

- We have built strong relationships with our network made up of over 400 trusted Partner Repairers across Australia. They are chosen based on skill, customer service, industry experience, facilities, and quality of workmanship.
- With our partner repairers, we know customers will get the highest standards of quality, safety and service. Our Partner Repairers can be located at www.cgu.com.au/partnerepairers.
- Please note that for each repairer listed in your search, we confirm we have a relevant interest in them, meaning there is a financial, contractual or other arrangement between us.

CHOICE OF REPAIRER

- You have a choice of repairer for your vehicle. Please refer to your policy documents for details.

HOW YOU CAN RESOLVE A DISPUTE WITH US

Our dispute resolution system is free and works like this:

1. Please advise the staff at your CGU Insurance office on 13 24 80 if you are dissatisfied with:
 - our decision on your claim
 - our handling of your claim
 - the services of our loss adjuster or investigator.
2. The staff member will try to resolve the problem.
3. If unable to resolve it, the staff member will refer it to the supervisor or manager for attention. A decision concerning your complaint will be made within 15 business days of receipt.
4. If this fails to resolve your problem, you may request that the problem be referred to our internal dispute resolution staff. They will investigate the dispute and try to reach a satisfactory outcome with you, normally within 15 business days of the date you requested a referral.
5. If you do not accept our decision, you may take the problem to the Australian Financial Complaints Authority (AFCA), for an independent investigation. The AFCA can assist with private consumer and some small business type claims.
6. The telephone number for the Australian Financial Complaints Authority is 1800 931 678.

More detailed information about this process is available from your CGU Insurance office.



CAR INSURANCE

CLAIM REPORT - THEFT

Please answer all questions. This will help us process your claim quickly. If you need more space to answer any of the questions, please use a separate sheet of paper. Any attachments will form part of this claim report and the declaration will include them.

1. Policy number (from your schedule)

Office use only

XS MP Cause

2. Insured (surname, company, partnership)

Contact person (for company or partnership claims)

3. Address

Postcode

4. Private telephone no.

Business telephone no.

Mobile no.

Email address

5. Are you registered for GST purposes?

No Yes

▶ What is your ABN?

Have you claimed or do you intend to claim an input tax credit on the GST applicable to this policy?

No Yes

▶ Is the amount claimed or intended to be claimed less than 100% of the GST applicable to the premium?

No Yes

▶ Specify the percentage amount claimed or intended to be claimed

 %

Are you entitled to claim an input tax credit for repairs or replacement of your vessel?

No Yes

▶ Is the amount claimable less than 100%?

No Yes

▶ Specify the percentage claimable

 %

Insured vehicle details

6. Description of the vehicle stolen

Registration or Identification number

Make, model & body type

Year of manufacture

Name of registered owner

Colour of vehicle

Engine No.

V.I.N.

Auto/Manual/other

How many sets of keys were supplied at the time of purchase?

Who has the keys now?

Who was in possession of these keys at the time of the theft?

From whom did you purchase your vehicle?

Name

Address

Postcode

Date

Price paid

7. Do you owe money on the vehicle?

No

Yes



Lender's name

Approximate amount owing

\$

Lender's address

Postcode

Private telephone no.

Business telephone no.

Facsimile no.

Loan account

Loan type

8. Has the vehicle been modified or converted from the manufacturer's specification or fitted with accessories other than those supplied by the manufacturer?

No

Yes



Describe the modifications/accessories

Was the vehicle locked before the theft?

No

Yes



Has the vehicle been fitted with an immobiliser or a car alarm?

No

Yes



Brand and model

Immobiliser

Alarm

9. What was stolen?

Vehicle

Contents or accessories



Please list

10. Was there any unrepaired damage to the vehicle before the theft?

No

Yes



Describe the unrepaired damage

11. What was the vehicle being used for before the theft (e.g. private use only, carrying goods in connection with business)?

Describe in detail the circumstances leading up to the theft

12. Where was the vehicle parked at the time of the theft?

Address

Postcode

13. When was the vehicle parked or last checked?

Date

Time

a.m.

p.m.

14. Who last saw the vehicle?

Full name

Relationship to insured (e.g. son, daughter, employee)

Address

Postcode

Private telephone no.

Business telephone no.

Mobile no.

15. Who discovered the theft and when?

Full name

Date

Time

a.m.

p.m.

16. What means of transport are you using now

Do you own another vehicle?

No

Yes

17. Do you know who was responsible for the theft?

No

Yes



State names and addresses or any other identifying information

18. To which police station was the theft reported?

Officer's name

Name of station

Date

Time

a.m.

p.m.

Who reported the theft?

Full name

19. Was the vehicle recovered?

No

Yes



a. Explain the circumstances surrounding the recovery (e.g. who, when, where)

b. If damaged, provide details

c. On this diagram please shade the areas damaged.

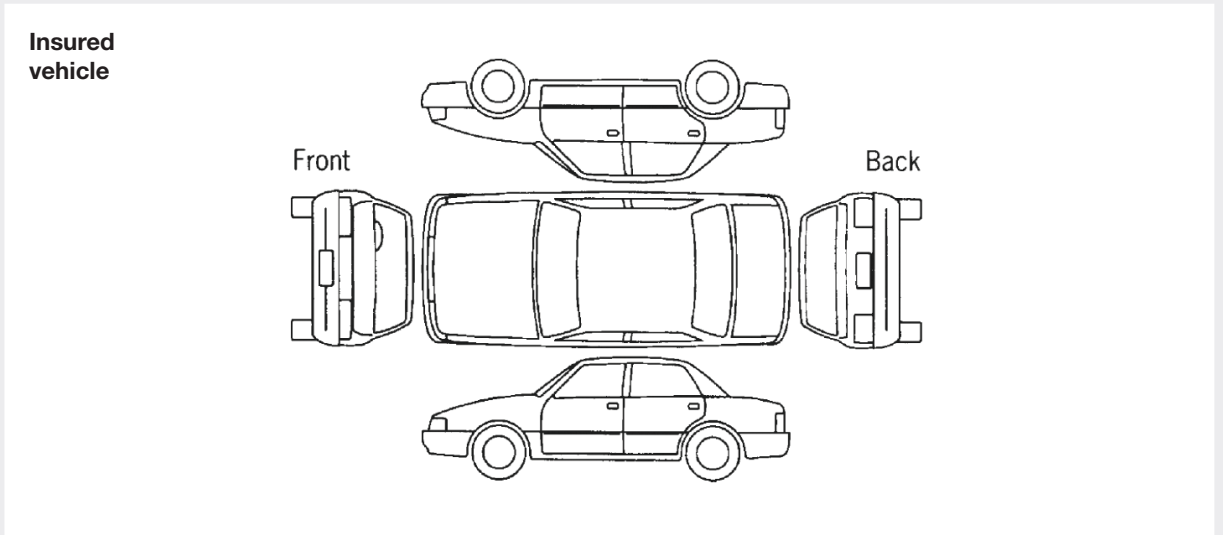

20. Have you been charged with, or convicted of, a motoring offence (other than a parking offence) or been disqualified from driving in the past five years?

No

Yes



State details

21. Have you ever had insurance refused or cancelled, had a renewal refused or had special conditions imposed by an insurer?

No

Yes



State details

22. Have you been charged with, or convicted of, any criminal offence in the past ten years?

No

Yes



State details

23. Have you had a car burnt or stolen, or claimed against an insurance company for damage to a car, in the past five years?

No

Yes



State details

Full name of person

Brief details (eg. hit other car in rear)

Was a claim submitted to your insurance company?

No

Yes



Declaration

I declare that to the best of my knowledge and belief the information in this form is true and correct and I have not withheld any relevant information.

I/we agree that, by submitting this form, the personal information I/we provide to CGU Insurance in this form or otherwise may be collected, held, used and disclosed in the manner set out in the CGU Privacy Policy found at www.cgu.com.au/privacy, including for processing this claim.

Signature of the insured or person with authority to sign for and on behalf of a company or partnership

Date

DD / MM / YY

Please indicate the number of additional pages attached to this claim report

When complete, please forward the report to:

Email - claims@cgu.com.au

Post - CGU Insurance, GPO Box 2852 MELBOURNE VIC 3001

or send it to us via your Agent or Broker

**Alternatively, claims can be lodged over the telephone 24 hours a day,
7 days a week by calling us on 13 24 80 (13 CGU 0)**

CONTACT DETAILS

ENQUIRIES 13 24 81
CLAIMS 13 24 80

MAILING ADDRESS
GPO BOX 9902 IN YOUR CAPITAL CITY

[CGU.COM.AU](https://www.cgu.com.au)

SYDNEY

GPO Box 244
Sydney
NSW 2001

MELBOURNE

181 William St
Melbourne
VIC 3000

BRISBANE

189 Grey St
South Bank
QLD 4101

PERTH

46 Colin St
West Perth
WA 6005

ADELAIDE

80 Flinders St
Adelaide
SA 5000



Insurer
Insurance Australia Limited
ABN 11 000 016 722 AFSL 227681
trading as CGU Insurance